

TEEAM Specialised Group - Trading

By the Chairman, Engr Leong Kam Seng

I wish to take the opportunity to thank the outgoing Committee and congratulate the incoming Committee for 2009 - 2011 session.

I have taken the liberty to list the following items for our mission:

- to practice 90 days payment
- to sell only compliance & safe product
- to have closer rapport with members through outings and sports
- to solve members' problems concerning regulations, approvals and standards
- to recruit more members

The activities proposed for 2009 are as follows:

- Talk by BRIS on financial report/ credit information / debt recovery
- Members' outings / gathering for sharing market information / networking / visit to orphanage
- Financial loans / grants
- Technical talks / training
- Trade visit / mission
- Dialogue session with authorities

Members are reminded to comply with Suruhanjaya Tenaga (ST)'s requirement on the 31 controlled items. The copy on controlled items can be obtained from the TEEAM Secretariat. A Committee will soon be set up to work with ST and the Association of Suppliers Against Fake Electrical Equipment, Kuala Lumpur (ASAFEE) to improve the compliance of the requirements.

Please give us suggestion/comments or raise your problems to the Committee Members at their contact numbers listed below or alternatively contact the TEEAM Secretariat directly:

Chairman	Engr Leong Kam Seng	019-267 8153
Vice Chairman	Ooi Eng Guan	012-375 0028
Secretary	Lim Ming Kow	012-392 5585
Asst Secretary	Leonard Choong Kin Loong	012-322 8876
Committee Member	Charles Lee Wai Chiew	012- 208 4518
Committee Member	Liew Ee Khai	013-341 3389
Committee Member	William Young Chee Keong	019-335 5247



SHAMAN SDN. BHD. (45706-K)

Established Since 1979

We are specializing in :-
HIGH TENSION ELECTRICAL WORKS
LOW TENSION ELECTRICAL & ENGINEERING WORKS
EXTRA LOW VOLTAGE WORKS
TELEPHONE WORKS
MECHANICAL WORKS
MAINTENANCE WORKS

REGISTERED WITH:-

- PKK (CLASS 1)
 - PKK CLASS A
 - TARAF BUMIPUTERA
 - CIDB (G7)
 - SURUHANJAYA TENAGA
- KEMENTERIAN KEWANGAN MALAYSIA
 - TENAGA NASIONAL BERHAD
 - TELEKOM MALAYSIA BERHAD
 - PUTRAJAYA HOLDINGS

KUALA LUMPUR : No. 277-3, Jalan Selinsing 7, Taman Niaga Waris, Off Jalan Kuching, 51200 Kuala Lumpur, Malaysia.
 Tel : 603 - 6258 4288, 6251 0595 Fax : 603 - 6251 6966 E-mail : mail@shaman.com.my

SABAH BRANCH : No. 12,1st Floor, Block B, Heritage Plaza, Jalan Lintas, 88000 Kota Kinabalu, Sabah.
 Tel : 088-712 133 Fax : 088-716 133 E-mail : kkoffice@shaman.com.my

Electricals

Galvanised Iron Conduit & EMT Fittings

Brass & Copper Wiring & Earthing Accessories.



Devi Impex Sdn. Bhd.

B-2-4, Block B, Megan Avenue 1
189 Jalan Tun Razak
50400 Kuala Lumpur
Malaysia
Tel: +6-03-2166 3044
Fax: +6-03-2166 2453
Website: www.aglfittings.com

Contact Person: Mr R.S Agrawal
H/P: +6-012-201 4196
E-mail: rsa@aglfittings.com

Intan Economic Lecture

On 20th February 2009, the National Institute of Public Administration, Malaysia (INTAN) organised an economic lecture on “Current Economic Crisis: What Malaysia Needs to get Back on Track”. Some 300 participants from universities, government agencies, public, various associations attended the lecture.

The presentation outline covered the global crisis, impact on the Malaysian economy, stabilisation measures and medium & long term solution. The speaker, YBhg Tan Sri Dr Sulaiman Mahbob, Director General of Economic Planning Unit (EPU), Prime Minister’s Department, Malaysia, highlighted the root cause of global economic crisis arisen from the subprime mortgage crisis which is an ongoing financial crisis triggered by a dramatic rise in mortgage delinquencies and foreclosures in the United States with major adverse consequences for banks and financial markets around the globe. The crisis which has its roots in the closing years of the 20th century, became apparent in 2007 and has exposed pervasive weaknesses in financial industry regulation and the global financial system.

Approximately 80% of US mortgages issued in recent years to subprime borrowers were adjustable-rate mortgages. When US house prices began to decline in 2006-2007, refinancing became more difficult and as adjustable-rate mortgages began to reset at higher rates, mortgage delinquencies soared. Securities backed with subprime mortgages, widely held by financial firms, lost most of their value. The result has been a large decline in the capital of many banks and USA



High profile lecture – Intan Economic Lecture by EPU.

government sponsored enterprises, tightening credit around the world.

Malaysia is not completely insulated from the global financial crisis. There are some measures implemented to maintain stability of the financial system & stimulate growth, such as:

- All ringgit & foreign currency deposits with commercial, Islamic & investment bank and DFIs are fully guaranteed by Government through Perbadanan Insurans Deposit Malaysia (PIDM) until December 2010.
- Extend guarantee to all domestic & locally incorporated foreign banking institutions.
- Access to BNM liquidity facility extended to insurance companies & takaful operators.
- To boost stock market, RM 5 billions (USD 1.4 billions) injected to Value Cap Sdn Bhd (special-purpose vehicle by government) to invest in undervalued companies.
- Overnight policy rate cut by 25 basis points to 3.25% & further 75 basis points to 2.5% to stimulate loans growth & lowering of

SRR from 4.0 % to 3.5% and further to 2.0% to inject more liquidity in the system.

For the next 6-12 months, it is necessary to undertake measures to strengthen economic resilience to cushion the impact from global economic slow down and to introduce RM7 billion stimulus package (savings from subsidies) will be a good stabilisation strategy:

- Sustain growth, ensuring resilient financial sector credit flows
- Promoting investment & new sources of growth
- Reprioritising 9th Plan projects
- Enhancing social safety net programme

There are some global efforts that can counter global slowdown, such as coordinated efforts to inject stimulus packages to jump start flagging economies, interest rates cuts, manage currency value and assistance to ailing industries.

There are some roles for private sector to face this challenge, such as to save jobs and avoid retrenchments, to improve competitiveness and continuous innovation (eg productivity, quality, cost and supply chain management innovation) for skilled workers who need to have training and retraining; for R&D and investment in technology; and cost efficient (eg 3R which stands for reduce, reuse, recycle).

Private sector has to secure new markets and focus on new product development and new sources of growth and to build in long-term market planning for long-term sustainability.

A copy of the presentation can be downloaded from the TEEAM website, www.teeam.com for reference.



SPECO BUMI ELEKTRIK SDN BHD

(Incorporated in Malaysia - 46174 - W)

MAIN OFFICE : PT 2581, BANDAR BARU, 35800 SLIM RIVER
PERAK DARUL RIDZUAN, MALAYSIA
TELEPHONE : 605-452 8915, 605-452 7980
FAX : 605-452 9129
EMAIL : specobumi@gmail.com

BRANCH OFFICE : 28, PERSIARAN KILANG,
KAWASAN PERINDUSTRIAN JELAPANG
30100 IPOH,
PERAK DARUL RIDZUAN, MALAYSIA.
TELEPHONE : 605-526 1028, 605-526 8028, 605-527 2028
FAX : 605-526 2028
EMAIL : specoipoh@yahoo.com
WEB : www.specobumi.com

WE ARE REGISTERED WITH SURUHANJAYA TENAGA,
CIDB & P. K. K.

We deal with:-

1. Mechanical & Electrical Maintenance Works etc.
2. General Electrical Wiring Works (Domestic & Industrial)
3. Control System Wiring
4. High & Low Voltage Overhead Installation and Under Ground Cable
5. Public Road Lighting & Highmast Light
6. Special Lighting like Stadium and Area Flood Lighting, Stage Lighting etc.
7. Uninterruptible Power Supply System
8. Genset Maintenance & Installation Works
9. Energy Management System
10. Power Quality Audit



**MK6
(GENIUS)
Class 0.5s
& Class 1**



**MK3
Class 0.2s**



**DT862
3-Phase
4-Wire
Watt hour
Meter**



**HLD03
Single Phase
Watt hour
Meter**

JEAN MÜLLER 
the name for safety



**LV HRC
fuse-switch
-disconnectors**



**HV HRC fuse-links
(Current Limiting)**



**LV HRC fuse-links
(NH fuse system)**



Digital Power Meter



Switches



**Push Buttons,
Pilot Lights & LED**



Analogue Instruments



Total Metering Solution Sdn. bhd. (Co. No. 478265-H)

No. 22 & 22A, Jalan Anggerik Vanilla 31/93, Kota Kemuning, 40460 Shah Alam, Selangor, Malaysia.

Tel: +603-5122 0029 Fax: +603-5122 0079

Email: info@tms.com.my/sales@tms.com.my

Website: www.tms.com.my

State Associations News

Electrical Association of Sarawak & Sabah (EASS)

No. 2 A/F, 2nd Floor, Hardin Road, 96000 Sibul, Sarawak.
Tel: 6084-319 949 Fax: 6084-346 114, 325 112
E-mail: sccci@streamyx.com

30th Anniversary Dinner

Electrical Association of Sarawak & Sabah (EASS) celebrated its 30th anniversary at Sibul RH Hotel, Sarawak on 28th March 2009. The anniversary dinner was attended by YB Dato' Sri Wong Soon Koh (Second Minister of Finance cum Minister of Environment, Public Health & Local Government, Sarawak) and YB Dato' Amar Sri Hj Awang Tengah Ali Hassan (Second Minister of Planning & Resource Management cum Minister of Public Utilities, Sarawak).

EASS published a handbook on guides for safe working environment which was launched in conjunction with the celebration dinner. The handbook highlighted the tips for basic electrical safety rules/knowledge, precaution against electrocution, wiring regulation and electricity ordinance.

The EASS appealed to Dato' Sri Wong Soon Koh for a piece of land to build a new premises to improve its activities and to conduct more professional training courses. EASS successfully organised a few training courses throughout the years and have trained many electrician and technical personnel.

Dato' Sri Wong Soon Koh highlighted that Sarawak is implementing small type renewable energy plan and is encouraging the utilisation of solar energy, wind energy and mini hydro as well as bio-energy in order to provide a diversified solution and reduce the usage of mineral energy.

TEEAM Immediate Past President, Dato' Ir Lee Peng Joo represented TEEAM at the dinner. Dato' Lee highlighted the urgent need for the government to expedite the implementation of payment & the adjudication act for the construction industry to help solve the payment problem. He also advised EASS members to purchase genuine electrical products for consumer's safety.

Some 1,000 guests and members attended the grand dinner.



Support from the electrical fraternity – A well-attended celebration dinner organised by EASS.



Cake cutting ceremony – VIP guests invited on the stage to celebrate the happy occasion.



Launching of safety handbook – (2nd from right) Mr Hii Hua Chuon (EASS President) and (3rd from right) Guest of Honour, YB Dato' Sri Wong Soon Koh (Second Minister of Finance cum Minister of Environment, Public Health & Local Government, Sarawak) and (5th from left) Dinner Organising Chairman, Mr Tiong Chiong Kiing.



Sarawak Electrical Association

Lot 412, (2nd Floor), Lorong 11D,
Off Jalan Ang Cheng Ho, 93700 Kuching, Sarawak.
P. O. Box 1494, 93730 Kuching, Sarawak.
Tel: 6082 - 423 145 Fax: 6082 - 429 011
E-mail: btanhakkoon@yahoo.com

AGM & Election 2009

The Sarawak Electrical Association held its Election on 22nd May 2009. The President, Mr Bernard Tan was re-elected for the year 2009-2010.

Office Bearers for the year 2009 - 2010

Chairman	Bernard Tan Hak Koon
Vice Chairman 1	Chai Nyan Luke
Vice Chairman 2	Ling See Bing
English Secretary	Francis Chew
Chinese Secretary	Yeo Ngian Sock
Treasurer	Wong Foo Kok
Asst Treasurer	Sim Kheng Kui
General Affairs Officer	Then See Wee
Asst General Affairs Officer	Wong Kee Soong
Welfare Officer	Leong Kong Yoi
Asst Welfare Officer	Felix Jong
Recreation Officer	Liew Thiam Fat
Asst Recreation Officer	Ung Kah Kuok
Committee Members	Anthony Ting, Michael Chin Ling Koh Kiong, Ho Bee Huat Lee Kuok Tiong, Chang Loong Fatt Liew Jiew Fong, Morgan Thiam
Auditors	

Johor Bahru Electrical & Electronics Association

No.7-01, Jalan Bentara Luar, Taman Iskandar,
80050 Johor Bahru, Johor Darul Takzim.
Tel: 607 - 333 8174 Fax: 607 - 224 1923
E-mail: jatco@pd.jaring.my/
ibon_elec@yahoo.com



Training course

The Johor Bahru Electrical & Electronics Association (JBEEA) organised a training course on Electrical Fault Level on 12th May 2009. Some 20 members attended the course which was held at JBEEA's premises. The trainer Mr Lai Kok Wei was invited from ABB (M) Sdn Bhd.



Listen attentively – JBEEA members attended the course to improve their knowledge on electrical fault level.

Your Reliable Manufacturer & Partner For Electrical Wiring System & Accessories



High Impact uPVC Conduit



Conduit Fitting



Corrugated Conduit & Adaptor



Enclosure Box



Cable Slab



Round Duct



Underfloor Ducting System



Modular & Mini Trunking



Bending Spring

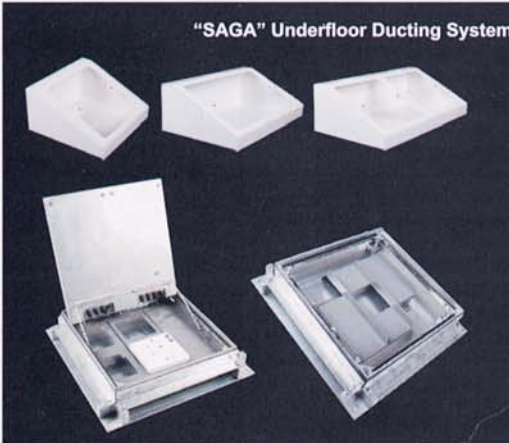

"SAGA" Underfloor Ducting System



EUROTAP Stretch 23

High Tension Tape & Line Tap



MCB Box



"EUROFAN" Ventilation & Exhaust Fan



NEW

Earth Tape Clip Heavy Duty Earth Chamber
Able To Withstand 8 Tons Loading



"MEGA" T5 & T5-8 Fluorescent Light



Watertight Flexible Conduit & Adaptor



"PVC-LINK" Cable Tie



"GJS" Cable Straight Joint



"EUROTAG" Tel DB & Tel Tag



UL "CHANGBAO" Halogen Free Heat Shrink



Wiring Accessories



"EUROSMART" Stainless Steel Cable Tie



Cable Gland



"MP" Termination Kit



Cable Marker & Marker Strip



Cable Roller & Wire Puller



Lot 1888, Jalan KPB 7, Kawasan Perindustrian Balakong, Bukit Belimbing, 43300 Seri Kembangan, Selangor D. E, Malaysia. Tel: 603-8962 3333 Fax: 603-8962 2266
Home Page: www.megapower.net.my E-mail: enquiries@megapower.net.my

..... Continue State Associations News



Penang Electrical Merchants' Association

No. 171A, Malacca Street, 10400 Penang.
Tel: 604 - 229 0195 Fax: 604 - 228 4233
E-mail: pema@streamyx.com
Website: www.pema.org.my

Golf Tournament 2009

The Penang Electrical Merchants' Association (PEMA) Golf Tournament 2009 was successfully held at the Bukit Jambul Country Club, Penang on 7th June 2009. A total of 74 golfers which included TEEAM Past President, Dato' Ir Donald Lim Siang Chai and Director of Energy Commission, Northern Region, Ir Md. Zakuan Hj Ibrahim participated in this tournament. The net proceeds of more than RM 4,000 from the tournament will go to the PEMA Education Fund which will be used to provide financial aids/scholarship to PEMA members' children who have achieved good results in their examinations. A big thank you was recorded to all the generous sponsors and the Organising Chairman, Mr Chee Soon Chin and Co-Chairman, Mr Lee Kuan Ming for ensuring that the tournament was smoothly organised.



Golfers posing before tee-off – A group photo for the album.

61st Anniversary Celebration Dinner

PEMA celebrated its 61st anniversary at the Forum Chinese Cuisine on 30th May 2009. Over four hundred guests and members attended the dinner celebration. PEMA President, Mr Teoh Yew Year in his opening address said that since 1948, PEMA has seen tremendous changes and achievements that reflect the transformation of Penang from an industrial state to a vibrant and key lifestyle destination of tomorrow. He is privileged to work in a team with outstanding, dedicated and committed professionals that have laid a strong and solid foundation during the past six decades. Highlights of the celebration were entertaining shows, piano orchestra, karaoke, lucky draw, presenting of certificate to new members and cake cutting.



PEMA 61st Celebration - Mr Teoh Yew Year (PEMA President) delivering his opening address.



Cake cutting ceremony - (centre) Mr Teoh Yew Year (PEMA President) and some PEMA Council Members.

61st Annual General Meeting

PEMA held its 61st Annual General Meeting (AGM) on 8th March 2009. PEMA President, Mr Teoh Yew Year in his opening speech said that the AGM is an opportunity to prompt the ownership into action as it belongs to all the members. He said that with the current economic crisis, members' endurance would be tested again and he believed that members would be able to weather this financial storm. A resolution on the formation of the PEMA Honorary Award Committee was tabled and approved by the AGM. The Committee would select candidates for the PEMA Honorary Award in recognition of members who have contributed significantly to the Association. The meeting also adopted the minutes of the previous AGM held on 15th March 2008, annual report 2008 and the audited accounts for the year ended 31st December 2008. After the AGM, a sumptuous lunch was hosted by PEMA for all attendees.

Other State Association Members' contacts:



The Perak Electrical Association

No. 12-A, Jalan Datuk Mahmud,
31650 Ipoh, Perak Darul Ridzuan.
Tel: 605 - 254 1502 Fax: 605 - 250 9145
E-mail: multi99@streamyx.com



Negeri Sembilan Electrical Engineering Association

c/o No. 194, Jalan Pantai, 71000 Port Dickson.
Tel: 606-647 1105 Fax: 606-647 4728



Malacca Electrical Contractors and Traders Association

No. 389-G1, Taman Pringgit Jaya,
Jalan Mata Kuching, 75400 Melaka.
Tel: 606 - 283 8688 Fax: 606 - 781 1466



Sabah Electrical Association

Lot No. 3-3-R, Beverly Hills Plaza, Jalan Bundusan,
88300 Kota Kinabalu, Sabah.
Tel: 6088 - 712 358 Fax: 6088 - 717 358
E-mail: pes233@tm.net.my / pes233sabah@gmail.com
pes233sabah@streamyx.com

Sandakan Electrical Engineering Association, Sabah

Block A, Lot No. 1, 2nd Floor, Bandar Tong Huat,
Batu 3, Jalan Utara, 90000 Sandakan, Sabah.
Tel: 6089 - 213 978 Fax: 6089 - 213 978
E-mail: suntronic_sdk@yahoo.com



**COPPER SHEET
COPPER STRIP &
COPPER BUS BAR**



**ENAMELLED
COPPER WIRE**



**INSULATING
PAPER, SHEET, BOARD**

MODEL 5556-1

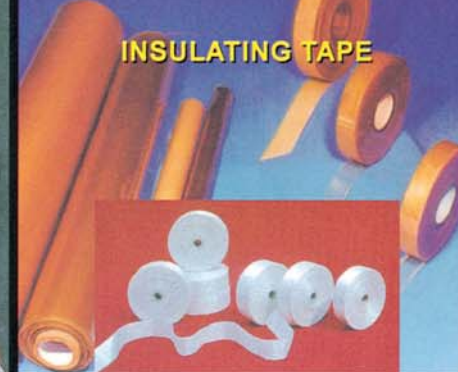

INSULATING TAPE



INSULATING FILM

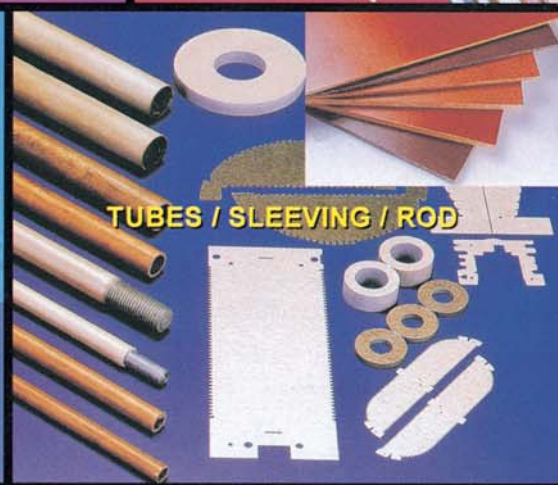

TUBES / SLEEVING / ROD

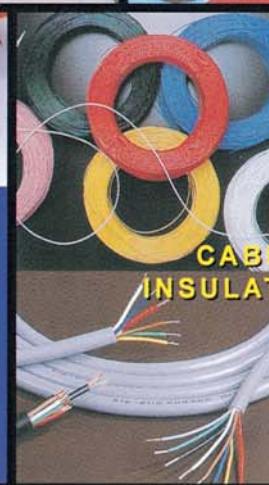

**CABLE AND
INSULATING WIRE**

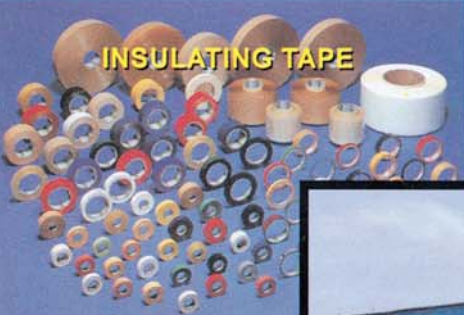

INSULATING TAPE



**PENGEDAR ALAT ELEKTRIK
STRIKER ELECTRIC SDN. BHD.**
前鋒電器有限公司



**前鋒電器有限公司
STRIKER ELECTRIC SDN. BHD.** (86357-A)

Lot 2, Jalan P 10/15, Kawasan MIEL Bangi Phase IV, Bangi Industrial Area,
43650 Bandar Baru Bangi, Selangor Darul Ehsan.
Hunting Line: (603) 8922-1188

Fax: (603) 8922-1818(Sales), 8922-2828 (Account)

E-mail: sstriker@streamyx.com Website: www.striker.com.my

SABAH BRANCH: Tel: 088-421488 Fax: 088-439488

**STOCKIST AND DISTRIBUTOR OF IMPORTED AND LOCAL-COPPER BARS, STRIPS,
ENAMELLED COPPER WIRE, INSULATING MATERIALS, ELECTRICAL & ETC.**



**INDUSTRIAL
EXHAUST FAN**



TERMINAL & CONNECTOR



SOLDERING IRON, BIT & ELEMENT

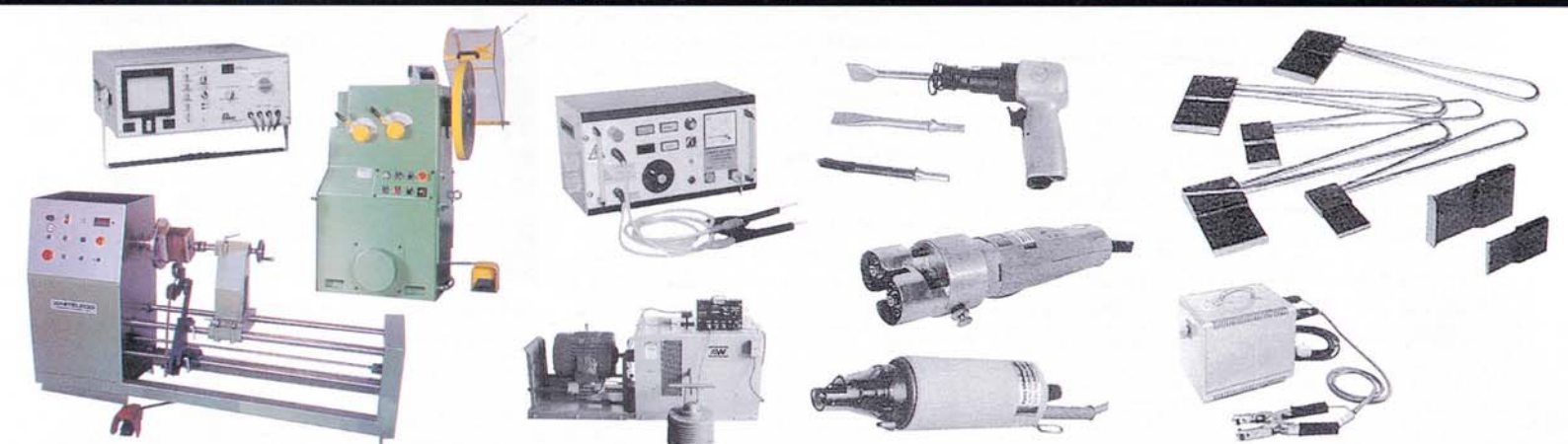

Challenges and Opportunities in Electrical Industry - Part 11

This paper is prepared by Ir Chew Shee Fuee, TEEAM Vice President.

Cable Lugs Contribute to Energy Efficiency

- **MS 1540:2002** - Specification for the Materials, Markings and Dimensions of Crimp Type Cable Lugs for use with Copper Conductor in Low Voltage Application.
- **MS 1779:2005** - Crimp Type Cable Links as Through Connectors and Stranded (Non-Compact) Copper Conductor in Low Voltage Application - Specification for the Materials, Markings and Dimensions

The above two standards were developed by TEEAM. The correct usage and proper cable lugs will improve electrical supply reliability as well as efficiency.

We understand that the limiting factor in the distribution of power is not only the cable but the accessories. There is improvement required in the selection and usage of proper cable lugs. The general trend of using low priced cable lugs can be detrimental to the electricity distribution. Poor and improper cable lugs will cause hotspots and eventually cause serious damage to the connection and even the switchboard.

Non-standard cable lugs may cause heating and this will be a power loss in the system. If many such connections are found in the system the cumulative effect can be significant. These losses can be recovered by using the correct and standard cable lugs.

It is therefore advantageous to deploy the usage of good and correct standard cable lugs in order to achieve the most efficient manner of power distribution.

Digressing a little, I would like to remind everyone that cable entry to switchboards must be effectively covered. Cases of rats, snakes and others entering switchboards are still found to be happening. The consequences are very damaging to the switchboards.

Programme on Environmental Management for Malaysia - Promotion of Energy Efficiency

TEEAM and the Association for Overseas Technical Scholarship (AOTS), Japan will be organising another training course in Japan this year. The course will be held from 9th to 20th November 2009. In view of the favourable response from our participants last year we will encourage you to apply for this year's course. Places are limited to 25. The estimated cost per participant is RM 6,500.00 which will take care of all costs including the flights. The training course is subsidised by AOTS via the Japanese government. Visits to companies developing energy saving products and where energy efficiency is put into use will be included in the training. In view of the need to emphasise on energy efficiency it is most relevant to those who require the first hand knowledge from the Japanese.

Task Force on High Voltage Testing Laboratory

It has been the request by the industry to the government to set up Electrical Testing Facility so that our manufacturers need not pay a very high cost to send their equipment overseas for type testing. Although we have some testing facilities but the current

shorting tests on most electrical equipment are not available in the region. The Ministry of International Trade and Industry, Malaysia (MITI) has set up a task force on this matter. We hope with the setting up of local testing laboratories our local manufacturers will be able to improve their product quality by using the facility for R&D other than the normal type testing purpose. We appreciate your input on the items for test that are not locally available so that we can feed this information to the task force.

GBI Certifier & Facilitator

The Malaysia's Green Building Index (GBI) was launched on 21st May 2009. The GBI Malaysia rating is based on the following 6 key criteria:

1. Energy Efficiency
2. Indoor Environment Quality
3. Sustainable Site Planning and Management
4. Materials and Resources
5. Water Efficiency and
6. Innovation

With the above in mind there is therefore the necessity to have GBI Certifiers and Facilitators. The prerequisites for the two categories can be found at www.greenbuildingindex.org.

Ir Chew Shee Fuee B.Sc. (Hons) (Strathclyde), PEng, CEng, FIEM, MIEE Member, IEEE Member, 1st Grade Electrical Engineer (Competent up to above 500 kV).

Ir Chew is the Vice President (Engineering Construction and Services) of The Electrical and Electronics Association of Malaysia (TEEAM). He was TEEAM President for 2001 - 2003 and 2003 - 2005. He is the Past President of the Asean Federation of Electrical Engineering Contractors (AFEEC).

Ir Chew is the Managing Director of G. H. Liew Engineering (1990) Sdn Bhd and QATM Engineering Services Sdn Bhd. He graduated from the University of Strathclyde, Glasgow with a B. Sc (Hons) in Electrical & Electronics Engineering. He is a Professional Engineer and is also licensed by Energy Commission as a competent engineer (without voltage limits) and a service engineer to carry out electrical testing up to a voltage of 500 kV.

Ir Chew has 26 years experience in electrical control and relay protection. He is also specialised in electrical site tests on power equipment, electrical fault investigation, service and maintenance of electrical switchgear and relays. His work also includes electrical supervision of substations and electrical audit. He presents lectures on electrical apparatus and the protection system. He can be reached at E-mail: sfchew@ghliew1990.com





The brand you can trust

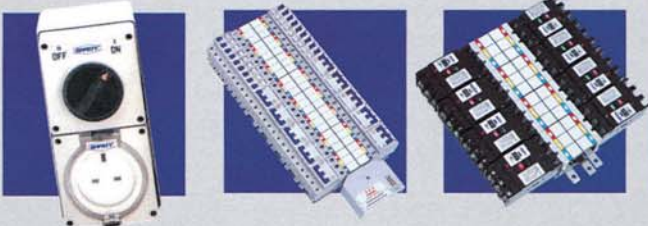

Products Certification & Approval
ASTA Certificate - LV Switchboard, MCB & MCCB Busbar System
International IEC Certificate - MCB and ELCB
Suruhanjaya Tenaga Approval - LV Switchboard, MCB & ELCB
 Our LV Switchboard, MCB and ELCB is approved for Government Projects



<p>3 Pole Socket for Vertical Busbars Ampere: 100A, 160A, 250A, 400A and 630A</p>	<p>Withdrawable Starter Panel</p>	<p>25A Auxilliary Plug and Socket</p>	<p>63A 6 Pole Plug and Socket</p>	<p>Busbar Support For Vertical Busbar</p>	<p>Outgoing 3 Pole Plug and Socket with Protection Cover, Ampere: 100A, 160A, 250A, 400A and 630A</p>



Manufacturer :

TEKNIK
 KEJURUTERAAN LTRIK
 TEKNIK (M) SDN. BHD.
 (Company No. 60122T)

Lot 10, Jalan Halba 16/16, 40000 Shah Alam, Selangor Darul Ehsan, Malaysia.
 Tel: 603-5519 0888 Fax:603-5519 9333, 5519 0777
 E-Mail: safety@teknik.com.my URL:http://www.teknik.com.my

Marketing :

ISA
 INDUSTRI SHA ALAM
 SDN. BHD.
 (Company No. 170416U)

New Members

The following new members have been approved and accepted by the TEEAM Council (as at 8th May 2009). A warm welcome to all the new members and special appreciation is extended to those who introduced these new members. For those who are not yet members..... why wait? Join us and find out how our Association can offer our services to you.

<p>RBA Engineering (M) Sdn Bhd No. 44-1, Jalan 2A/27A, Seksyen 1, Wangsa Maju, 53300 Kuala Lumpur. Tel: 603-4143 4094 Fax: 603-4142 0581 E-mail: rba.engineering@gmail.com Contact Person: Encik Nasruhakim Bin Rahman <i>Business: Construction and services.</i></p>	<p>Standard Electric Sdn Bhd TB 12878 & 12879, Lot D1 & D2, Sedco Light Industrial, Mile 3½, Apas Road, P. O. Box No. 902, 91008 Tawau. Sabah. Tel: 6089-912 929 Fax: 6089-912 099 E-mail: stde@tm.net.my / stde_sb@yahoo.com.my Contact Person: Mr Pang Ah Foh <i>Business: M & E contractor.</i></p>
<p>ELK Sdn Bhd No. 36 & 36A Jalan 17/155C, Bandar Bukit Jalil, 57000 Kuala Lumpur. Tel: 603-8994 9266 Fax: 603-8994 9220 Email: elksdnbhd@yahoo.com Contact Person: Mr Low Kong Ee <i>Business: Electrical Contractor.</i></p>	<p>Patron Power Sdn Bhd 9197-8, Jalan TTP 1/36, Taman Industri Puchong, 47100 Selangor Darul Ehsan. Tel: 603-8060 0229 Fax: 603-8060 0525 Email: patron@tm.net.my Contact Person: Mr Cheong Sang Weng <i>Business: Electrical Engineering.</i></p>
<p>Eplan Competence Center S.E.A. Unit 705, Block G, Pusat Gagangan Phileo Damansara 1, No. 9, Jalan 16/11, Off Jalan Damansara, 46350 Petaling Jaya, Selangor Darul Ehsan. Tel: 603-7954 5525 Fax: 603-7954 5528 E-mail: joanne.leong@eplan.com.my Website: www.eplan.com.my Contact Person: Mr Mak Jyh Yoong <i>Business: CAE software solutions provider.</i></p>	<p>My Lighting (M) Sdn Bhd No. G-16, Jalan Putra Perdana 5E, Taman Putra Perdana, 47100 Puchong, Selangor Darul Ehsan. Tel: 603-8319 1668 Fax: 603-8319 2668 E-mail: mylighting2u@yahoo.com Website: www.mylighting2u.com Contact Person: Mr Den Yang <i>Business: Light fixtures wholesales and importer, lighting projects.</i></p>
<p>Data Control Technology Sdn Bhd No. 21-C, Jalan 6/10, Taman Komersial, Pandan Indah, 55100 Kuala Lumpur. Tel: 603-4295 5128 Fax: 603-4295 5219 E-mail: info@datacontrol.com.my Website: www.datacontrol.com.my Contact Person: Mr Ho Kang Chai <i>Business: Extra low voltage services.</i></p>	<p>Orimicro Alloys Sdn Bhd Lot 1030, Jalan Bukit Angkat, Kampung Bukit Angkat, Sungai Chua, 43000 Kajang, Selangor Darul Ehsan. Tel: 603-8734 3888 Fax: 603-8734 2888 E-mail: orimicro@streamyx.com Website: www.orimicro.com.my Contact Person: Mr Chih Tsung Liang <i>Business: Trading and manufacturing of high-tech precision steel.</i></p>
<p>Aik Loung Land & Marine Electric Motor Works Sdn Bhd Lot 1063, Kemena Commercial Centre, Tanjung Batu Road, 97000 Bintulu, Sarawak. Tel: 6086-332 421 Fax: 6086-332 500 E-mail: bintulu@aikloung.com Contact Person: Mr Wong Aik Loung <i>Business: M & E contractor.</i></p>	<p>High Stand Electrical Sdn Bhd No. 14A, Jalan Cerdik, Taman Connaught, Cheras, 56000 Kuala Lumpur. Tel: 603-9100 3626 Fax: 603-9100 3627 E-mail: h-stand@streamyx.com Contact Person: Mr Melvin Lee <i>Business: Contractor.</i></p>
<p>CME Power Engineering Sdn Bhd No. 26, Jalan BPU 8, Bandar Puchong Utama, 47100 Puchong, Selangor Darul Ehsan. Tel: 603-5882 4171 Fax: 603-5882 4179 E-mail: cmepower_2003@yahoo.com Contact Person: Mr Ng Choo Kau <i>Business: M&E testing, consultancy and engineering services.</i></p>	<p>Bernard Lim Kee Weng 8-2-1, Desa Daya, Persiaran Bukit Jambul, 11900 Penang. Mobile: 012-478 6032 E-mail: berna_rd@ieee.org <i>Business: Manufacturing of electrical appliances, electronics component/products and lightings.</i></p>
<p>Incontrol Tech Sdn Bhd No. 15, Jalan BRP 9/1D, Perusahaan Bukit Rahman Putra, 47000 Sungai Buloh, Selangor Darul Ehsan. Tel: 603-6157 8050 Fax: 603-6157 8060 E-mail: info_KUL@incontrol-tech.com Website: www.incontrol-tech.com Contact Person: Mr Jasbinder Singh a/l Kehar Singh <i>Business: SCADA, automation system and control relay panels.</i></p>	<p>IPSH Sdn Bhd No. 8, Jalan PJU 3/46, Sunway Damansara Technology Park, 47810 Petaling Jaya, Selangor Darul Ehsan. Tel: 603-7803 9260 Fax: 603-7803 1035 E-mail: hong.kw@ipsh.com.my Website: www.ipsh.com.my Contact Person: Mr Hong Kong Wai <i>Business: Trading and marketing engineering parts.</i></p>
<p>Multi-B Sdn Bhd Lot 53, Jalan Jasmine 2, Bandar Bukit Beruntung, 48300 Serendah, Selangor Darul Ehsan. Tel: 603-6028 1818 Fax: 603-6028 4899 E-mail: enq@multib.com.my Website: www.transliteinc.com Contact Person: Mr Danny Chong <i>Business: Busduct manufacturer.</i></p>	<p>Jasa Integrasi Sdn Bhd No. 29A, Jalan TS 6/10A, Taman Industri Subang, 47510 Subang Jaya, Selangor Darul Ehsan. Tel: 603-5632 0950 Fax: 603-5632 0960 E-mail: jasa.integrasi@gmail.com Website: www.jasaintegrasi.com Contact Person: Mr Ronnie Tan Kee Yaw <i>Business: ELV system solution provider.</i></p>
<p>Maxlux Electric Sdn Bhd No. 106 & 106A, Jalan Raja Uda, Pusat Perniagaan Raja Uda, 12300 Butterworth, Pulau Pinang. Tel: 604-323 7722 Fax: 604-324 2622 E-mail: maxlux@tm.net.my Contact Person: Mr Chiam Yeong Kang <i>Business: Lighting and electrical products.</i></p>	<p>Kian Projects (M) Sdn Bhd No. G-11, Jalan Desa Cahaya 11, Taman Desa Bukit Cahaya, 56100 Cheras, Selangor Darul Ehsan. Tel: 603-9105 6355, 9105 6377 Fax: 603-9105 6733 E-mail: kp_sb@tm.net.my Contact Person: Mr Low Liong Kian <i>Business: Contractor.</i></p>

New Books in Our Library

Informative reference materials are available in our Library. The Library is open to members from 9:00 am to 5:45 pm, Monday to Friday.

<p>Title : ACCCIM Bulletin, April 2009 Publisher : The Associated Chinese Chambers of Commerce and Industry of Malaysia</p>	<p>Title : Construction Quarterly Statistical Bulletin, Fourth Quarter 2008 Publisher : Construction Industry Development Board Malaysia</p>	<p>Title : Productivity Report 2008 Publisher : Malaysia Productivity Corporation</p>
<p>Title : ACEM Directory 2009 Publisher : Association of Consulting Engineers Malaysia</p>	<p>Title : EUMCCI Review, April 2009 Publisher : European Union-Malaysia Chamber of Commerce and Industry</p>	<p>Title : SUARA Perunding, 1st & 2nd Quarter 2009 Publisher : Association of Consulting Engineers Malaysia</p>
<p>Title : Annual Report 2008 Publisher : PEMUDAH (The Special Task Force to Facilitate Business)</p>	<p>Title : FMM Directory 2009, 40th Edition Publisher : Federation of Malaysian Manufacturers</p>	<p>Title : TEEAM Members Directory 2009/2010 Publisher : TEEAM</p>
<p>Title : Annual Report 2008 Publisher : PEMUDAH (The Special Task Force to Facilitate Business)</p>	<p>Title : HKECA Newsletter, April 2009 Publisher : Hong Kong Electrical Contractors' Association</p>	<p>Title : Tenaga Link, Vol 4/08 Publisher : Tenaga Nasional Berhad</p>
<p>Title : Average Unit Prices of Building Material for Civil Engineering Works Publisher : Department of Statistics Malaysia</p>	<p>Title : IEEMA Journal, June 2009 Publisher : Indian Electrical & Electronics Manufacturers' Association</p>	<p>Title : The Ingenieur, May-June 2009 Publisher : Board of Engineers Malaysia</p>
<p>Title : Building Material Cost Index for Building Works and Structural Works Publisher : Department of Statistics Malaysia</p>	<p>Title : Malaysia International Trade & Industry Report 2008 Publisher : Ministry of International Trade and Industry Malaysia</p>	<p>Title : Trademart, May-June 2009 Publisher : Malaysia External Trade Development Corporation</p>
<p>Title : Berita KLSCCCI, January – March 2009 Publisher : The Chinese Chamber of Commerce & Industry of Kuala Lumpur and Selangor</p>	<p>Title : Master Builders Journal, 4th Quarter 2008 Publisher : Master Builders Association Malaysia</p>	<p>Title : Singapore Supporting Industries 2009/2010 Publisher : Singapore Information Services Pte Ltd</p>
<p>Title : CIDB News, Issue 1/2009 Publisher : Construction Industry Development Board Malaysia</p>		<p>Title : What's New from Malaysia Publisher : Malaysia External Trade Department Corporation</p>



..... Continue New Members

<p>Speed Drives & Automation Sdn Bhd No. 29, Jalan BP 6/3, Bandar Bukit Puchong, 47100 Puchong, Selangor Darul Ehsan. Tel: 603-8061 3212 Fax: 603-8061 5668 E-mail: speeddrv@streamyx.com Website: www.speedrives.com Contact Person: Mr James Ngun <i>Business: Trading & engineering in frequency inverter, power supply units, automation & control components, electronics repairing and industrial automation projects.</i></p>	<p>Ampmech Industries Sdn Bhd No. 46, Jalan SS 22/21, Damansara Jaya, 47400 Petaling Jaya, Selangor Darul Ehsan. Tel: 603-7727 3417 Fax: 603-7727 3376 E-mail: ampmech@ampech.com Website: www.ampmech.com Contact Person: Ir Quah Ewe Hock <i>Business: Stocking distributor specialising in industrial & ex plugs and sockets, equipment for explosive atmospheres, instrumentation and process equipment.</i></p>
<p>Peninsular Steel Galvanising Sdn Bhd Lot 22198 Bukit Kemuning Batu 8 ½, Jalan Kg. Jawa, 40460 Shah Alam, Selangor darul Ehsan. Tel: 603-5121 2560 Fax: 603-5121 3976 Email: johngng@psg.com.my Website: www.psg.com.my Contact Person: Mr John Ng Jinn Yeong <i>Business: Hot-dip galvanising steel products & services.</i></p>	<p>Southern Pipe Industry (M) Sdn Bhd No. 4457, MK 15, Jalan Chain Ferry, 12100 Butterworth, Pulau Pinang. Tel: 604-331 7393 Fax: 604-331 9435 E-mail: contact@spim.com.my Website: www.spim.com.my Contact Person: Mr Scott Seow Chai Hock <i>Business: Manufacturing of ERW steel pipes.</i></p>





A **Complete System** in circuit protection



UTAMA

SWITCHGEAR SDN BHD

UTAMA SWITCHGEAR SDN BHD (416650-H)

No. 3, Jalan USJ 19/4A, UEP Subang Jaya, 47620 Petaling Jaya, Selangor Darul Ehsan, Malaysia

Tel 603-8024 1215 **Fax** 603-8024 1796 **Email** utamasb@streamyx.com

TEEAM Specialised Group - Engineering Construction & Services

By the Chairman, Ir Chew Shee Fuee

My sincere personal thanks and appreciation to members of the Engineering Construction and Services Committee for electing me to the post of Chairman.

The construction sector is always very challenging and there are many areas of concern faced by all members. TEEAM has effectively represented the interests of its members. The current status of TEEAM in the representation of the electrical contractors is well-recognised in the industry.

In order to uphold the industry to the position that is acceptable and well acknowledged by the society we need to continue in ensuring the quality of work and the application of safe and good electrical equipment.

The usage of low quality, substandard and unsafe equipment must be completely eliminated. Clients are to be informed on the application of safe and good quality equipment for the benefits to all. Technical requirements cannot be compromised on the matter of cost.

We have local manufacturer of good quality cable lugs. These cable lugs are made in accordance to the Malaysian Standards on cable lugs. The correct cable lug is very important to the power distribution. The cable capacity will be limited by poor connections and terminations. Hotspots will occur if poor termination is made with substandard cable lugs. Therefore it is not advisable to use cheaper cable lugs in order to save cost. Please take note of the need to use proper cable lugs and correct termination of cable ends.

We understand that our members face difficulties dealing with large corporations which impose specifications in the selection of some components in the electrical installation. Recently we were informed of a banning of batteries from a specific country. We regard the action taken is extremely unfair and penalise the import of other good quality batteries.

TEEAM and the Association for Overseas Technical Scholarship (AOTS), Japan are organising a training course on "Management & Implementation of Energy Efficiency &

Renewable Energy for Malaysia" in Japan from 9th to 20th November 2009. Basing on favourable feedback from the participants last year, we hope you will actively participate in the training this year.

With the launching of the Malaysia's Green Building Index (GBI) we are expected to be aware of the application of energy saving apparatus to help to achieve awareness of environmental preservation. Energy efficiency is a requirement in the Green Building Index. There will be the need for GBI certifiers and facilitators. We will work with these new professionals.

Being members of the same industry and association it is our obligation to seek to improve payment terms in the electrical trade. We will support our Trading Committee in the improvement to payment terms so that we can have a stronger and sustainable industry. The traditional long payment terms need to be revised and shortened accordingly. It will be in our common interest to adhere to the payment terms.



Building Wiring Installer Course

Introduction

The Building Wiring Installer training programme is designed for the construction personnel involved in the low voltage installation of electrical wiring and related electrical equipment. It is also a skill standard developed by the Construction Industry Development Board (CIDB) with participation of industrial experts from the public and private sectors. The Course is sponsored by CIDB subject to prior approval.

Course Duration & Language

Training lessons are conducted in Bahasa Malaysia from Monday to Friday, 10:00 am to 5:00 pm, over a period of 3 months.

Course Content

1. Fundamentals of electricity

Series and parallel circuits. Measurement units. Supply sources. Single phase and Three phase.

2. Wiring cables

Types, size, colour code, rating and applications. Conductor and insulator. Current carrying capacity and voltage drop. Types and methods of electrical wiring joint.

3. Protective devices

Fuse, miniature circuit breaker and earth leakage circuit breaker. Overload relay.

4. Read and interpret drawings

Electrical layout diagram. Schematic diagram. Wiring circuit diagram. Electrical symbols.

5. Electrical wiring

Concealed and surface wiring. Conduit and trunking. Surface and flush mounting. Lighting and power final circuits. Consumer terminal unit. kWh meters and earthing system.

6. Installing electrical equipment and appliances

Water heater, door bell, discharge lamp, exhaust fan, distribution board, etc.

7. Use measuring and testing instrument

Voltmeter, ammeter, clamp tester, multi-tester, insulation tester, earth resistance tester, etc. Principle of operations and applications.

8. Practical safety measures

Apply first aid treatment. Hazardous environment. Safe usage of tools and equipment. Report accidents on-site. Acts and regulations.

Certificate

Course participants who have achieved the skill competency requirement will be awarded with a certificate. In addition, a CIDB Green Card will also be issued.

For registration and further information, please contact the TEEAM Secretariat at:

Tel: 603-9221 4417, 9221 2091

E-mail: teeam@po.jaring.my

Website: www.teeam.com



旺電器木料有限公司

(6943-D)

WONG ELECTRICAL & TEAK WOOD SDN. BHD.

8, Lorong Yap Hin, Pudu, 55100 Kuala Lumpur, Malaysia.

Tel: 603-2142 5822 (Hunting Lines), 603-2142 9218/2148 4742 Fax: 603-2142 4523/2142 2846

Email: wetkl@wongelectrical.com.my Website: www.wongelectrical.com.my

Wong Electrical & Teak Wood (Pg) Sdn. Bhd. (30263-T)
No. 13 Jalan Pantai
10150 Pulau Pinang
Tel: 604-229 2571, 2519, 3996, 3686
Fax: 604-229 3613

Branch: 28, Lengkok Kikik 1
Taman Inderawasih
13600 Prai Pulau Pinang
Tel: 604-398 0720
Fax: 604-398 0855

Wong Electrical & Teak Wood (Sel) Sdn. Bhd. (75423-D)
No. 33 Jalan 20/14
Paramount Garden
46300 Petaling Jaya Selangor
Tel: 603-7874 8355(HL), 8251, 8135, 7876 2676
Fax: 603-7876 7175

Soon Fay Sdn. Bhd. (56058-U)
No.13, Jalan Kalong
Off Jalan Sungai Besi
55200 Kuala Lumpur
Tel: 603-9221 6011(HL), 3313,
6759, 7036, 1264, 1262
Fax: 603-9221 0743

Wong Lighting (M) Sdn. Bhd. (72038-P)
No 17 & 19, Lorong Yap Hing
Off Jalan Pasar, Pudu 55100 Kuala Lumpur
Tel: 603-2145 6788(HL), 2145 0591
2145 0590
Fax: 603-2145 6799

Branch: No. 34 Jalan 20/16A
Paramount Garden
46300 Petaling Jaya Selangor
Tel: 603-7876 5022(HL), 7874 2409,
7876 0879, 7874 2452
Fax: 603-7876 5057

TEEAM Specialised Group - Trading

By the Chairman, Engr Leong Kam Seng

I wish to take the opportunity to thank the outgoing Committee and congratulate the incoming Committee for 2009 - 2011 session.

I have taken the liberty to list the following items for our mission:

- to practice 90 days payment
- to sell only compliance & safe product
- to have closer rapport with members through outings and sports
- to solve members' problems concerning regulations, approvals and standards
- to recruit more members

The activities proposed for 2009 are as follows:

- Talk by BRIS on financial report/ credit information / debt recovery
- Members' outings / gathering for sharing market information / networking / visit to orphanage
- Financial loans / grants
- Technical talks / training
- Trade visit / mission
- Dialogue session with authorities

Members are reminded to comply with Suruhanjaya Tenaga (ST)'s requirement on the 31 controlled items. The copy on controlled items can be obtained from the TEEAM Secretariat. A Committee will soon be set up to work with ST and the Association of Suppliers Against Fake Electrical Equipment, Kuala Lumpur (ASAFEE) to improve the compliance of the requirements.

Please give us suggestion/comments or raise your problems to the Committee Members at their contact numbers listed below or alternatively contact the TEEAM Secretariat directly:

Chairman	Engr Leong Kam Seng	019-267 8153
Vice Chairman	Ooi Eng Guan	012-375 0028
Secretary	Lim Ming Kow	012-392 5585
Asst Secretary	Leonard Choong Kin Loong	012-322 8876
Committee Member	Charles Lee Wai Chiew	012- 208 4518
Committee Member	Liew Ee Khai	013-341 3389
Committee Member	William Young Chee Keong	012-278 0146



SHAMAN SDN. BHD. (45706-K)

Established Since 1979

We are specializing in :-
HIGH TENSION ELECTRICAL WORKS
LOW TENSION ELECTRICAL & ENGINEERING WORKS
EXTRA LOW VOLTAGE WORKS
TELEPHONE WORKS
MECHANICAL WORKS
MAINTENANCE WORKS

REGISTERED WITH:-

- PKK (CLASS 1)
 - PKK CLASS A
 - TARAF BUMIPUTERA
 - CIDB (G7)
 - SURUHANJAYA TENAGA
- KEMENTERIAN KEWANGAN MALAYSIA
 - TENAGA NASIONAL BERHAD
 - TELEKOM MALAYSIA BERHAD
 - PUTRAJAYA HOLDINGS

KUALA LUMPUR : No. 277-3, Jalan Selinsing 7, Taman Niaga Waris, Off Jalan Kuching, 51200 Kuala Lumpur, Malaysia.
 Tel : 603 - 6258 4288, 6251 0595 Fax : 603 - 6251 6966 E-mail : mail@shaman.com.my

SABAH BRANCH : No. 12,1st Floor, Block B, Heritage Plaza, Jalan Lintas, 88000 Kota Kinabalu, Sabah.
 Tel : 088-712 133 Fax : 088-716 133 E-mail : kkoffice@shaman.com.my



DIRIS[®] A, THE DEFINITIVE



> Plug-in optional modules



DIRIS A20 & A40

MADE TO MEASURE

- > Accurate measurement
 - Class 0,2 for currents & voltages
 - Class 0,5S IEC 61052-22 for kWh

- > Direct access & optimised visibility
 - 6 large direct access keys
 - Large LCD display
 - Blue backlit

- > Plug & display modules
 - Communications
 - Alarms
 - Analogues and digitals inputs / outputs
 - Memorization
 - Harmonics (spectral analysis)

- > Easy to install
 - Compact 96 x 96 x 60 mm
 - Test connection function
 - Simple fixing using retaining clips
 - Easy-to-use terminal blocks for fast cabling

Your contact



CONTROLS HANDLING ENGINEERING SDN BHD (38045 - U)
 2, Jalan Nilam 1/7, SUBANG HI-TECH INDUSTRIAL PARK
 40000 SHAH ALAM, SELANGOR DARUL EHSAN - MALAYSIA
 Tel: 603-5638 1166 (5 lines) - Fax: 603-5637 2766
 E-mail: controls@streamyx.com

MULTI-FUNCTION METER



Pulse outputs

2 pulse outputs able for configuration (type, weight and run) on \pm kWh, \pm kvarh and kVAh.



Pulse outputs and harmonics

2 pulse outputs able for configuration (type, weight and run) on \pm kWh, \pm kvarh and kVAh. Spectral analysis of harmonics by range and by phase for 3I, In, 3V and 3U up to range 25.



RS485 JBUS / MODBUS® communication

RS485 link with JBUS / MODBUS® protocol (speed up to 38400 bauds).



RS485 PROFIBUS® DP communication

RS485 link with PROFIBUS® DP protocol (speed up to 1.5 Mbauds).



Analogue outputs

2 outputs able for configuration on 3I, In, 3V, 3U, F, \pm Σ P, \pm Σ Q, Σ S, Σ PFL/C and 30 VDC power supply. 2 modules may be connected at maximum, that is 4 analogue outputs.



2 inputs - 2 outputs

2 outputs assignable for the control of 3I, In, 3V, 3U, F, \pm Σ P, \pm Σ Q, Σ S, Σ PFL/C, THD 3I, THD In, THD 3V, THD 3U and of the hour meter (storing of the 3 last alarms) or to the remote control. 2 inputs for pulses metering. 3 modules may be connected at maximum, that is 6 inputs / outputs.



Memory

- Storing maximum over 62 days of P+, P-, Q+, Q- with an internal or external synchronisation TOP of 5, 8, 10, 15, 20, 30 and 60 minutes.
- Storing of 10 hour-dated last alarms.
- Storing of minimum and maximum instantaneous last values for 3U, 3V, 3I, In, F, Σ P \pm , Σ Q \pm , Σ S, THD 3U, THD 3V, THD 3I, THD In.
- Storing of 10 last hour-dated (EN 50160 and IEC 61000-4-30): voltage dips, over voltage, voltage cut off.
- Storing of 3U, 3V and F average values based on synchronisation function (maximum 60 days).



CONTROL VISION Software

SIRENA Made in Italy

Audible and visual warning devices



Industry - Security - Marine and Explosion-Proof

Sole Distributor:

東源電器機械有限公司

THUNG GUAN ELECTRICAL MACHINERY SDN. BHD. (71574-X)

Kuala Lumpur Main office

No. 8 & 10, Jalan Gandek, Off Jalan San Peng, 55200 Kuala Lumpur, Malaysia.

Tel: 603-9221 1811 (4 Lines), 9211 1819, 9221 1910, 9222 2090 Fax: 603-9222 9014

E-mail: thung_guan@hotmail.com

Klang office:

No. 54, Lebuhr Merpati, Off Jalan Meru, 41050 Klang, Selangor. Tel: 603-3341 4101 (H/Line) Fax: 603-3341 4077



To Consultants, Engineers, Contractors,
Project Managers, Purchasers

“Towards Safety and Energy Efficient Connection”

Comparison Between Standard & Non-Standard Bimetal Lug

500mm² Bimetal Lug

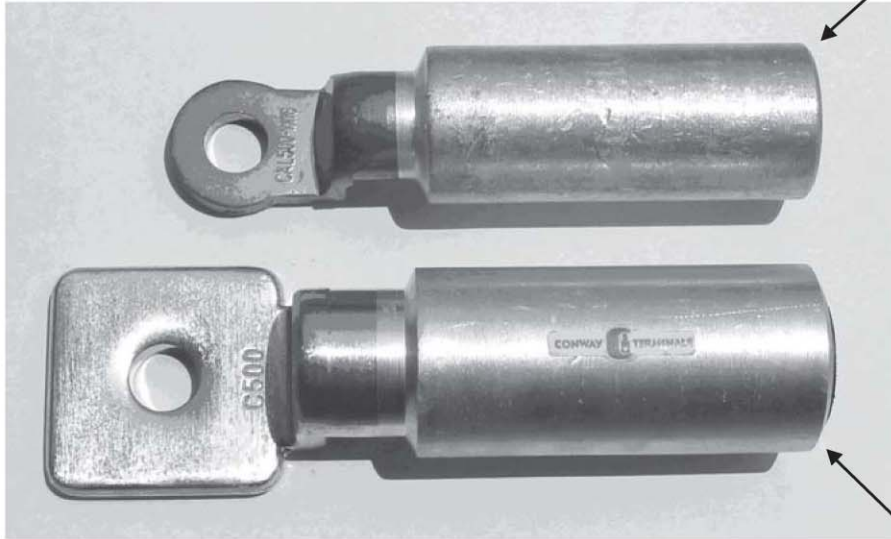

Non-Standard Bimetal Lug

Aluminium Barrel Thickness: 6mm
Weight: 412gram

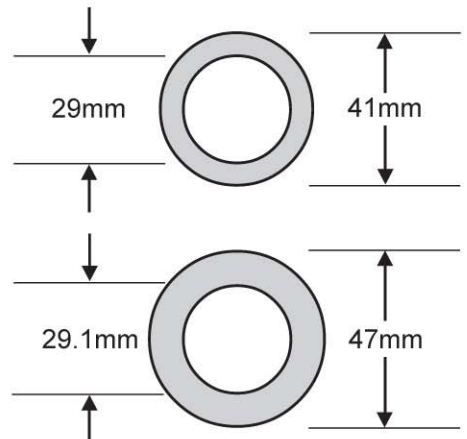

IEC Standard Bimetal Lug

Aluminium Barrel Thickness: 8.95mm
Weight: 823gram

300mm² Bimetal Lug

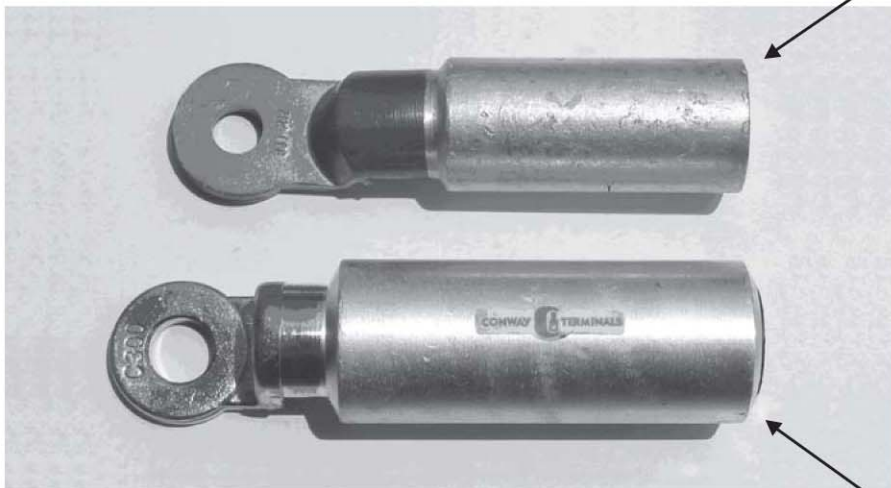

Non-Standard Bimetal Lug

Aluminium Barrel Thickness: 5.5mm
Weight: 317gram

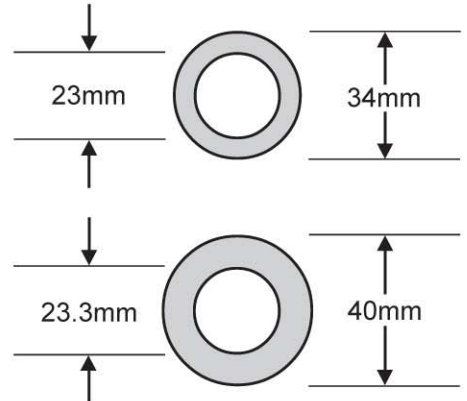

IEC Standard Bimetal Lug

Aluminium Barrel Thickness: 8.35mm
Weight: 411gram



For more information, please contact us at:

CONWAY TERMINALS MANUFACTURER SDN. BHD. (049613 U)

Lot 1298, Jalan Bukit Kemuning, 42450 Klang, Selangor, Malaysia

Tel: + 603-5122 1223/ 1068 Fax: + 603-5121 1109

E-mail: ctm@conway.com.my Website: www.conway.com.my

Make the most of your energy



+



=

Up to 30%
saving right now!

Today's technologies

A growing business

For you, 30% energy saving is achievable with today's technologies. Up to 40% of the potential savings for a motor system are realized by the Drives & Automation. Up to 30% of the potential for savings in a building lighting system can be realized via the lighting control system.

Find out how you can make the most of your energy
at www.schneider-electric.com or call us now at
1-800-880-877 or 603-7883 6238.

Schneider
Electric

Green Technology Applications in Current Environment

The paper is presented by Ir Dr F C Chan of Hong Kong Electrical Contractors' Association at the AFEEC/FAPECA Conference & Meetings 2009 held on 15th July 2009.

Abstract

This paper reviews the application of green technologies with an aim to combat climate change by enhancing energy efficiency and the use of renewable for end-user energy utilization. To establish a baseline, energy and carbon audits are conducted to identify various energy management opportunities. The use of green technology in each of these areas is examined. These technologies include lighting, heat and ventilation, lifts and escalators, and renewable. Replacement of existing or aged equipment and the use of performance contracting are considered particularly under the current financial situation. In this current environment, more efforts are required in order to ensure a sustainable environment for our future generations.

Introduction

Green technology is the applied science and engineering to conserve the natural environment and resources to enable a sustainable future. In applying green technology as a solution, it should be economically viable and environmentally sound. Currently, there are two major risks posed to the world today: the Climate Change and the Financial Tsunami. The financial tsunami affects the world economy and hence the pursuit of a more sustainable future might be affected. For example, research and applications of more energy efficiency application might suffer shortage of funds, small and medium companies might be out of operations due to cash flow problems. For those companies that can stay through the tsunami, they will care more on the environment, by making save in energy and hence money, by demonstrating corporate responsibilities thus enhancing their brand name, by influencing general public thus creating more business.

For preserving the environment, there are two approaches:

- (a) in the energy saving journey, there are two ways: 'don't waste when not in use' and 'do more with less'. In both of these cases, energy efficiency and energy utilization effectiveness can be achieved.
- (b) in the renewable energy aspect, 'free energy' is installed by capital investment which may not have a short pay back period

Energy and Carbon Audit

Before considering any green technologies, it is essential to carry out energy and carbon audits so that we know where we are. By establishing a baseline, we can then identify improvement opportunities and hence the required applications for better energy utilization.

Energy audit

Energy audit is an examination of an energy consuming equipment/system to ensure that energy is used efficiently. It looks for energy management opportunities for improvement. There are two types of energy audit: Walkthrough Energy Audit and Detailed Energy Audit, varying by the breadth and depth of the examination^[1].

Walkthrough Energy Audit is like a general health check, sparing only a fair amount of time and resources to review the general conditions of the energy equipment/system, operation and maintenance practices, identify & prioritise Energy Management Opportunities (EMOs) and make coarse estimate of the benefit & cost of EMO implementation.

Detailed Energy Audit is often carried out as an equipment-/system-specific energy efficiency study. The more complex and high-benefit-high-cost EMOs identified from walkthrough energy audit are candidates for detailed energy audit. The purpose of which is to develop practical engineering solutions with the benefit & cost of implementation thoroughly assessed. Detailed energy audit is usually accompanied with detailed analysis of historical system operating data and comprehensive field measurement of equipment/system energy efficiency performance, and thus requiring more time and resources to complete.

Carbon audit

Carbon audit is a means of measuring and recording the organisation's emissions of greenhouse gases (GHG) notably carbon dioxide CO₂ (also including methane, HCFC, etc. or the total called greenhouse gas equivalents). It is essential that if we want to reduce CO₂, we must establish a baseline to measure then to benchmark and hence control. The HKSAR Government issued a set of guidelines to account for and report on GHG Emission and Removals for Buildings (Commercial, Residential or Institutional Purpose)^[2].

At the start of the carbon audit, it is essential to determine the physical boundaries of the concerned building where the organisation is situated. After that, the operational boundaries are to be determined based on the organisation's operational activities. After identifying and defining the boundaries, the next step is to collect required relevant data. For example, lighting, air-conditioning, machinery, office equipment, industrial processes, fuel used, waster disposal etc. Under the guidelines, there are three separate scopes for consideration: scope 1, 2 and 3.

Scope 1 is to deal with the direct emission from sources and the removals by sinks. These include: Combustion of fuels in stationary sources, Combustion of fuels in mobile sources, Fugitive emissions and Removals of greenhouse gas. Scope 2 covers indirect emissions when using energy sources from electricity or gas.

Scope 3 covers indirect emissions for those activities the organisation required to conduct their business. Scope 3 activities may be implicit in nature and some quantification tables are required in order to calculate its emission equivalent. For example, the methane gas generated due to paper waste disposal, use of water where electricity is used for flesh water processing and hence its indirect emission, sewage as electricity is used for sewage treatment and hence its indirect emission. Other common activities under Scope 3 include: Transportation of purchased goods and materials, Employee travels, Outsourcing.

After collecting all relevant data based on the defined scope 1 to 3 elements, the GHG emission quantity can be calculated with relevant to some published conversion factors. As data collection may be done by a number of parties, it is therefore necessary to make required engineering judgment to validate such data and hence their meanings so derived. Since different sectors may have different energy consumption and process, the qualified registered engineers should be able to provide their expert view and reduction approach for the organisation to adopt. It is a great challenge for conducting the first carbon audit and setting out the associated reduction plan.



S-A5 Series

Superior technology, design and usage.



S-A9 Series

Where function matches style without sacrificing performance and safety.



Contemporary Series

Perfectly matched in metallic gold, silver and green to meet any interior.



Ultra Series

Sound engineering and quality that imparts confidence.



Switch to the new Time Era 'Lightstyle'

Not Just Any Switch

Time Era's new 'lightstyle switches' are ideally suited for domestic, commercial and industrial use. They are stylish, colourful, perfectly functional and reliable. All our products are quality tested and endorsed for safety and consistency.



TIME ERA SDN. BHD.

(A Subsidiary of EDEN INC. BERHAD)

(A member of Zil Group of Companies)



Green Technologies Applications

After carrying energy and carbon audits, a list of potential improvement areas can be found. Based on the audit results, we can prioritise the items for enhancement. These improvement areas include lighting, mechanical ventilation and air conditioning, lifts and escalators, water and space heating, cooking, control and energy management systems, building design and finally, renewable energy technologies.

Lighting

Lighting contributes quite a major portion of energy usage and is one of the areas where easy energy reduction can be achieved. Lantern replacement can be a straight forward approach, particularly where incandescent lamps replacement in some countries are mandatory. With the development LED technology which is the future of lighting, complete replacement of conventional lighting is not far away. Of course, re-design the lighting provision based on the LED characteristics may be required. Care must be taken in the LED provision because of its colour changing capabilities as additional lighting might be provided to demonstrate the vivid of a metropolitan city. The role of lighting control is getting more and more important. The use of photo sensors and programmable logic controllers can further enhance the energy saving performance of lighting system. The potential saving under this category is given in the following table.

Applications of Green Technology in Lighting	Energy saving potential
- Compact Fluorescent Lamps to replace incandescent lamps	~80%
- Energy efficient fluorescent tubes (electronic ballasts, T5 tubes) to replace electromagnetic ballasts & T8 tubes	~30%
- LED exit signs to replace conventional exit signs that use fluorescent tubes	~80%
- Coated reflector – achieving comparable lighting level using specially coated reflector but with less lamps	30%, depending on the number of lamps removed

Mechanical Ventilation & Air Conditioning

Energy evaluation by different energy models shows that the central seawater scheme (seawater cooled) and cooling tower scheme (fresh water cooled) are more energy efficient than the conventional air-cooled air-conditioning scheme depending on the building type, air-conditioning plant configuration and piping layout. Water cooled chillers can provide better efficiency than the air-cooled ones. Fresh water cooling towers can provide an effective solution as the more efficient coppers tubes can be used in the condenser to achieve a higher efficiency. The use of variable speed drive devices in fans and pumps enhance the system efficiency.

Applications of Green Technology in Mechanical Ventilation & Air Conditioning	Energy saving potential
- Water-cooled chillers to replace air-cooled chillers	~30%
- Automatic tube cleaning system that keep heat exchange surface in chiller efficient heat transfer	~10-15%
- Variable speed fans & pumps (eg Variable speed drive (VSD) for secondary chilled water pumps, VSD for regulating supply & exhaust air fans through detecting CO ₂ or CO concentration)	~10-30%
- Heat wheel to recapture energy from cooled exhaust air stream to supply air stream	Recover ~40% energy
- Proper air-balancing (ratio between exhaust & make-up air) in kitchen to reduce cooled air escape through kitchen exhaust.	Case varies, depending on level of shortfall in makeup air

Lifts & Escalators

It is essential that the application of voltage optimiser and high efficiency motors can be applied to minimise the energy waste. Of course, some form of intelligent detection system by sensors or image recognition can be applied.

Applications of Green Technology in Lifts and Escalators	Energy saving potential
- Variable voltage variable frequency drive for regulating escalator's motor torque and speed at light load	~10%
- Intelligent detection system for escalator	Case varies, depending on utilisation pattern

Water & Space Heating

The electric heat pump with a high Coefficient of Performance (COP) is the most effective way in hot water production. It makes use of the heat from the environment, normally obtained either from air or from the chilled water return, to generate more heat energy.

Many commercial and industrial process processes require hot water or steam. Different kinds of water heaters are equipped to heat up water to the desired temperature.

Applications of Green Technology in Water and Space Heating	Energy saving potential
- Heat pump water heaters to replace direct heating electric or gas-fired boilers	~70%
- Fuel-fired boiler air-fuel optimisation controller to ensure complete combustion and minimising heat loss caused by over supply of air	~5%
- Heat recovery device (optimisation) at flue gas exhaust of fuel-fired boiler for process water / process air pre-heating	~5%

Cooking

In terms of energy saving, electric induction cooking is more efficient than the gas-fired cooking. In addition, a more safe and comfort kitchen environment can be provided.

Applications of Green Technology in Cooking	Energy saving potential
- Electric induction cooktops, woks and stoves to replace equivalent gas-fired equipment	~60-80%

Control and Energy Management Systems

In order to have better control and manage the energy utilisation, timers, occupancy sensors, photo sensors to keep air-conditioning or lighting active only on needed basis can be developed. Where appropriate, some decision support tools can be incorporated so that the system can learn from the past utilisation experiences as well. For these control system applications, the energy saving potential may be varied from case to case.

Building Design

In the building design, application of solar film on windows or double glaze windows to shield against incident heat from incident sunlight but allow light to pass through, thus saving energy on air-conditioning can be achieved. It is estimated that some 70% of the heat can be blocked. Green roof is another approach where culturing plants at roof top to reduce transmitted from roof. The effectiveness depends on building locality, geometry and orientation.

Renewable Energy

Renewable energy is normally sustainable and energy efficient. It highly depends on the availability of the resources. In the case of Hong Kong, solar and wind power are the two most popular renewable energy applications.

Ex-Or manufactures lighting controls for all applications encompassing, presence detection and lighting management systems. The Ex-Or Managed Lighting System (MLS Digital) is the most intelligent, efficient, cost-effective and installer friendly lighting system available today.

Ex-Or MLS Digital can be used to:

- Save Energy and Save Money
- Enhance the working environment
- Ensure compliance with Health and Safety Legislation

Tax incentives for using energy efficiency products by Malaysian Industrial Development Authority (MIDA) or the Energy Commission (ST)

Start conserving energy today and save mother earth. It's time for a better lighting management system. It's time for Ex-Or Innovative Lighting Management Systems by MK Electric.



In the wake of global energy crisis, Malaysia particularly has increased its electricity tariff rate by 18% for households and 26% for some commercial and industry users effective July 2008.

www.ex-or.com
www.mkelectric.com.my



The Ex-Or range of Lighting Management Systems includes:

MLS Digital
 Building-wide Managed Lighting System

CONNECT
 Quick Connection Systems

LightSpot
 Lighting control by presence detection and photocell



Innovative Lighting Management Systems
 by **MK Electric**



..... Continue Green Technology Applications in Current Environment

For solar energy, photovoltaic (PV) panels can be installed on roof to transform solar energy into electrical energy. The energy can be grid-connected for other application usage. Solar energy can be transformed into thermal energy by means of solar heating panels of heat pipes. The efficiency is higher than the PV panels and extremely suitable to be an alternate energy source to the existing central hot water plant.

Small scale wind turbines are also suitable for building roof-type applications. Wind turbines turns wind energy into electrical energy and again connected back to the system for other electrical appliances. Normally, the power output is low and suitable for light load application such as lighting. A combination of wind turbine and solar panels are common for some outdoor lighting poles applications.

Performance Contracting

For large scale energy efficient projects or renewable energy application, normally, capital investment is required. In view of the recent economic situation, it may be a huge barrier for the initial investment. The application of performance contracts may help to solve the problem.

Performance contracting is to leverage the energy so saved for installing energy efficient equipment to pay for the capital investment. Little or zero upfront may be required from the owner and the energy service company will build the energy saving project. The energy cost saved from the new system will then be measured and verified by the energy service company. The verified saving will then be shared between the owner and energy service company to payback the project cost. The plant performance is normally guaranteed so that the owner is very confident to carry out the project. The performance contracts will end when the project is fully paid back. After that, the owner will enjoy the entire saving generated from the new energy efficient plant.

Conclusion

Considering the two major risks currently in the planet, the financial tsunami is a matter of confidence while the risk associated with the

climate change is imminent requiring everyone to act by reducing greenhouse gas emission. We have to save energy bit by bit to achieve no more wastage in order to save our planet.

In the application of green technology as described above, some form of capital is required particularly when the application may have long payback duration. Performance contracting approach can be adopted particularly when a reputable provider can offer a green solution where the initial capital investment can be reduced. Of course, a balance consideration must be adopted in term of the useful life of existing facilities and replacement these facilities by higher efficiency equipment to achieve the desired energy saving potential. The result obtained from the energy and carbon audits will be a good baseline for making this green application decision on those energy saving improvement areas. Application of green technology and techniques can provide a solution for a sustainable future to combat the climate change.

References

- (1) The HKSAR Environmental Protection Department and Electrical and Mechanical Department (2007) "Guidelines to Energy Audit"
- (2) The HKSAR Environmental Protection Department and Electrical and Mechanical Department (2008, Jul.) "Guidelines to Account for and Report on Greenhouse Gas Emissions and Removals for Buildings (Commercial, Residential or Institutional Purposes) in Hong Kong."

Ir Dr F C Chan B.Sc., M.B.A., M.A., L.L.M., Ph.D., D.I.C., F.H.K.I.E., R.P.E., C.P. Eng., F.I.E.(Aust.), Sen. M.I.E.E.E., P.M.P.

Ir Dr F C Chan received his education in both Hong Kong and United Kingdom. He is currently the General Manager of CLP Engineering Limited. He has extensive experiences in power systems specialising in power system protection, distribution automation, lighting applications and energy services. Ir Dr Chan is active in various learned society activities in Hong Kong. He is currently the Honorary Treasurer of the Hong Kong Electrical Contractors' Association.

He can be reached at hkeca@biznevigato.com



Badminton Tournament 2009



Mark your
Calendar

Date : 13th & 20th December 2009
 Time : 9:00 am – 6:00 pm
 Venue : Michael's Badminton Academy
 Bandar Puteri, Puchong,
 Selangor Darul Ehsan.

Registration: Contact TEEAM Secretariat
 Tel : 603-9221 4417, 9221 2091
 Fax : 603-9221 8212
 E-mail : teeam@po.jaring.my /
teeam@streamyx.com
 Website: www.teeam.com

NIKKON®

Light up the World

Complete Industrial Lighting Solution Provider

Light – an incredible tool which serves to identify, guide, emphasis, decorate, increase safety and illuminate.

Industrial Lighting



- Street Lighting



- Highbay



- Lowbay



- HID Ballast & Ignitor
Certified by CE, SIRIM, TNB, JKR, SESCO
- Floodlight
- Architectural Lighting
- Lighting Accessories



Malaysia Exclusive Distributor



A member of



Success Electronics & Transformer Manufacturer Sdn Bhd [SETM] was established in 1980 and, through our dedicated commitment to customer satisfaction and innovation over the years, we are now one of the largest low-voltage transformer and industrial lighting manufacturers in Malaysia. SETM is wholly owned by Success Transformer Corporation Berhad, which is the first company of its kind to be listed on the Main Board of Malaysia's securities exchange, Bursa Malaysia.

We are one of the largest ISO9001 accredited low voltage transformer manufacturer in Malaysia, providing a comprehensive range of low voltage transformers. We also supply a large volume of industrial lighting to both domestic and international markets. SETM manufactures transformers and industrial power products such as automatic voltage stabilisers, power line conditioners, energy-saving lumens regulators, high intensity discharge [HID] ballasts, battery charger and testers. We also make industrial lighting products such as floodlights, highbay and street lighting.

Trusted Brand in Transformers

Our commitment is our consistency in the design, manufacturing and delivering of highly reliable products at all times.

Electrical Apparatus



- Automatic Voltage Stabilizer



- Energy Saving Lumens Regulator



- Harmonic Circuit Filter Reactor



- Variable Voltage Transformer
- Power Transformer
- Motor Starting Auto Transformer
- Line Reactor



New Series *Metasol* ACB

LS Industrial Systems

New Name of  **LG Industrial Systems**

LS Industrial Systems introduces an extensive line of automation, control and power distribution products - all designed, manufactured and tested with cutting edge technology to meet extreme environmental conditions and global specification requirements.



Product Overview

LS Industrial Systems has been the market leader for industrial control and automation products in Korea for decades and is now offering these advanced technology products in Malaysia. For information on their complete line of PLCs, AC Inverter drives, HMIs, Motor Control or Switchgear products, please contact our authorized distributors listed below or visit our website at www.lsis.biz



Contactors & Breakers



AC Drives



PLC & HMI

Authorized Distributor:

SUN POWER AUTOMATION SDN BHD (639503-W)

Lot 28242, Kampung Jaya Industrial Area, 47000 Sungai Buloh, Selangor, Malaysia.

Tel: 603-61577555 Fax: 61577666 E-mail: general@sunpowerholdings.com.my



SUN POWER SYSTEM SDN BHD

Leader In Electrics & Automation

Power Transmission & Distribution

LS Cast Resin Transformer



**Capacity (KVA)
Single Phase
20 ~ 2,000KVA**

**Capacity (KVA)
Three Phase
50 ~ 8,000KVA**



**Rated Voltage: Up to 36kV
Rated Frequency: 50, 60 Hz
Conductor: Copper,
Aluminum
Insulation Class: B, F, H**



**Applicable standards:
IEC60076 – 11
ANSIC57.12.01**



**% Impedance Voltage ANSI Standard 5.75%
(Others are available by request) IEC Standard 4 ~ 6.00%**

Authorized Distributor

SUN POWER SYSTEM SDN. BHD.

Lot 28242, Kampung Jaya Industrial Area, 47000 Sungai Buloh, Selangor, Malaysia.

Tel: 603-615 77 555 Fax: 603-615 77 666 E-mail: sun_power_system@yahoo.com

LS Industrial Systems
New Name of  LG Industrial Systems

QUALITY PRODUCTS

by



CABLE JUNCTION BOXES
DISTRIBUTION BOARDS
CIRCUIT BREAKER BOXES
LV SWITCHGEAR ASSEMBLIES

CABLE JUNCTION BOXES



- High quality
- Ratings up to IP65
- Knock-out or elastic membrane cable entries
- Halogen-free and weatherproof versions
- UL/CSA approvals
- Fire resistant versions
- Wide range of sizes and terminal configurations
- Color-grey and black (orange for fire resistance)



NEW

HAZARDOUS AREA



- In accordance with ATEX 100A
- For use in zones 2 and 22

DISTRIBUTION BOARDS



- High quality
- Ratings up to IP65
- Knock-out or elastic membrane cable entries
- 3-9:12-36 & 12-54 modules
- Empty boxes and KWH meter boxes available



NEW

LOW-VOLTAGE SWITCHGEAR ASSEMBLIES

- Up to 1000A
- Up to IP 65 protection
- Class II total insulation
- Full Type Tested

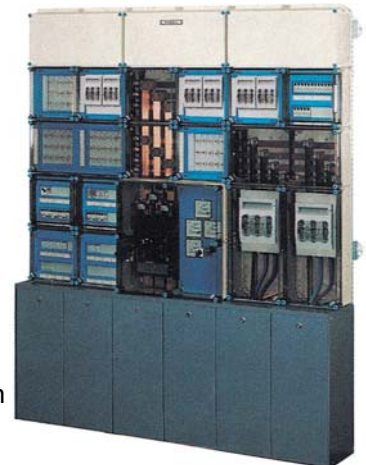

THESE PRODUCTS SUPPLEMENT AN EXTENSIVE RANGE OF CIRCUIT PROTECTION DEVICES AND INDUSTRIAL PLUGS & SOCKETS



Pentapower

Pentapower (M) Sdn Bhd (342805-A)

107, Jalan Puteri 5/3, Bandar Puteri Puchong, 47100 Puchong, Selangor Darul Shsan
Tel: 603-8062 6635 Fax: 603-8062 4635 E-mail: sales@pentapower.com.my

Website: <http://www.pentapower.com.my>

Green Building Index Malaysia

Green Building Index (GBI) Malaysia is introduced by Pertubuhan Akitek Malaysia (PAM) and the Association of Consulting Engineers Malaysia (ACEM). It is a profession driven initiative to lead the Malaysian property industry towards becoming more environment-friendly. GBI Malaysia is intended to promote sustainability in the built environment and raise awareness among developers, architects, engineers, planners, designers, contractors and the public about environmental issues. The rating system will provide opportunity for developers to design and construct green, sustainable buildings that can provide energy savings, water savings, a healthier indoor environment, better connectivity to public transport and the adoption of recycling and greenery for their projects.

GBI Malaysia is a rating system that provides a comprehensive framework to evaluate the environmental impact and performance of buildings. Buildings are awarded the GBI Malaysia rating based on six key criteria:

- Energy Efficiency
- Indoor Environmental Quality
- Sustainable Site Planning and Management
- Material and Resources
- Water Efficiency
- Innovation

GBI Malaysia Certification Awards

GBI Malaysia seeks to reward buildings that set out to achieve targets in any of the above six areas. Achieving points in the targeted areas will mean that the building will likely be more environment-friendly than those that do not address the issues.

Under the GBI Malaysia assessment framework, points will also be awarded for achieving and incorporating environment-friendly features which are above current industry practice.

The assessment process involves an assessment at design stage leading to the award of the provisional GBI Malaysia rating. Final award is given one year after the building is first occupied. Buildings will also have to be re-assessed every three years in order to maintain their GBI Malaysia rating to ensure that buildings are well-maintained.

Buildings are awarded GBI Malaysia Platinum, Gold, Silver or Certified ratings depending on the scores achieved.

GBI Malaysia will provide an assessable differentiation to promote environment-friendly buildings for the future of Malaysia. It is a benchmarking rating system that incorporates internationally recognised best practices in environmental design and performance.



www.greenbuildingindex.org

Sustainable Living Tips

How Can I Help?	Why Does It Matter?
Energy <ul style="list-style-type: none"> • Turn off the lights, air-conditioning and television and reduce unnecessary electrical use. • Try alternative Green renewable energy for some or all of your electricity. • Use energy-efficient lighting appliances and hot water services. • Use fans, openable windows for cross ventilation, insulation and sun-shading devices to cool your homes. 	Our energy use is often wasteful and can impact the environment through green house emissions that contribute to climate change. Sourcing for increasingly depleting natural resources also leads to further damage to sensitive environments.
Transport <ul style="list-style-type: none"> • Walk, cycle or use public transport where possible. • If you use a car, try to car pool with friends or co-workers. • Optimise car use activities to reduce your car trips. • Consider the option to live, learn, work and play within the community or locality of your home. • Consider buying a fuel efficient car and service it regularly. • Consider living in an area that has public transport options. 	Improving the way we go about our daily lives can reduce fuel use, which decreases pollution like smog and green house gas emissions, while reducing household costs and saving time.
Waste <ul style="list-style-type: none"> • Avoid excess packaging and use a reusable bag when shopping. • Recycle packaging and bags. • Donate unwanted items to charities. • Use compost systems or worm farms for food scraps and garden wastes. • Correctly dispose of household hazardous wastes and batteries. • Do not litter or discharge wastes into the waterways and surroundings. 	Avoiding waste where possible, encouraging reuse, recycling and proper waste disposal are all ways to reduce the community's impact on the environment. Proper disposal also helps keep our surroundings clean, healthy and beautiful.
Water <ul style="list-style-type: none"> • Reduce wasteful water use, <i>i.e.</i> have shorter showers, self-closing taps. • Fix faulty plumbing and install water wise showers and taps. • Consider changing to low-water-use appliances such as washing machines and toilets. • Grow a water wise garden. • Consider installing a rainwater tank for watering the garden or external cleaning purposes. • Don't throw rubbish into drains and waterways. • Implement soil erosion and proper drainage to areas where earth has been disturbed to prevent siltation of waterways. • Preserve and maintain natural water courses and catchment areas. 	Waste-free and wise water use helps maintain adequate fresh water resources for the community and the environment.
Lifestyle <ul style="list-style-type: none"> • Change to a healthier diet and lifestyle. • Exercise regularly or play a sport. • Get to know your neighbours and help keep your community safe. • Visit your health practitioner for regular check-ups. • Think about sustainability when purchasing or improving your home. • When you can, buy locally and purchase locally made goods and produce. • Further learning and developing new skills are great ways to challenge yourself and meet other people. 	Good community health, more sustainable green rated buildings and homes, and a more supportive society can contribute to the community's health and sustainability.
Environment <ul style="list-style-type: none"> • Join in litter cleanup activities. • Report any illegal dumping or open burning. • Report any illegal logging, mining or destruction of the natural environment. • Enjoy the natural environment and recreational areas through healthy activities such as walking, jogging, hiking, climbing, boating, swimming, snorkeling and diving. • Be responsible to preserve local flora and fauna. 	A healthy sustainable environment creates and allows its communities to recreate in it. It is an important heritage to be kept for future generations.



**“Electrical Sales Executives”
&
“Electrical Entrepreneurs”**

wanted by

**SAMAJAYA ELECTRICAL
TRADING SDN BHD**

(Company No. 839447-D)

Interested? Kindly forward
your details to

Tel & Fax : 1700-80-6818

SAMAJAYA

SAMAJAYA ELECTRICAL TRADING SDN BHD (839447-D)

22, Jalan Gandek, Off Jalan San Peng, 55200 Kuala Lumpur.

Tel: 603-9223 6818 (Hunting Line) Fax: 9223 7818

E-mail: enquiry@samajaya.com.my Website: www.samajaya.com.my

AGENT • DISTRIBUTOR • STOCKIST

Tel : 603-92236818 Fax : 603-92237818

Metal & Plastic DBs 	Cable Support Systems 	Cables & Wires 	Capacitors 
Rotary & Change Over Switches 	Explosion Proof Fittings 	GI, PVC & Corrugated Pipes 	HV Switchgears 
Test & Measuring Instruments 	Lamps 	Lighting Luminaires 	Lightning Conductor & Columns 
LV Switchgears 	Joint & Termination Kits 	Electrical Accessories 	Electrical Accessories 



CUSTOMER CARELINE : 1700 80 6818



Power Measurement, Control and Protection Solutions



Protector Trip Relays

The Cubicle Onload Changeover Switch (63A - 3105A, 415V, AC - 23A)



an Indo-French joint venture

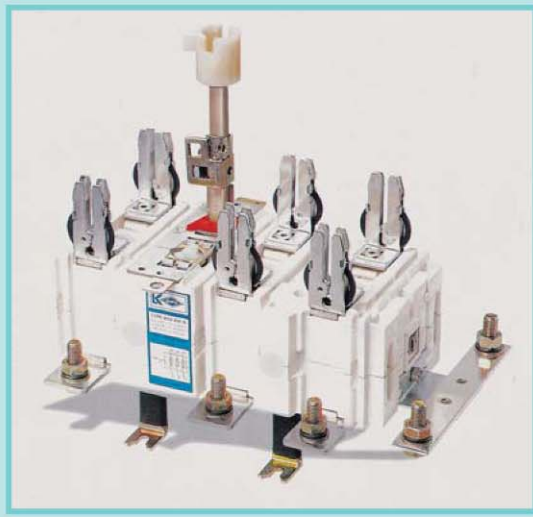

Switch Disconnecter Fuse